

Kardanlager

Kardanlagerflansch

zur Lagerung eines Kardanadapters oder eines Schwenklagers.

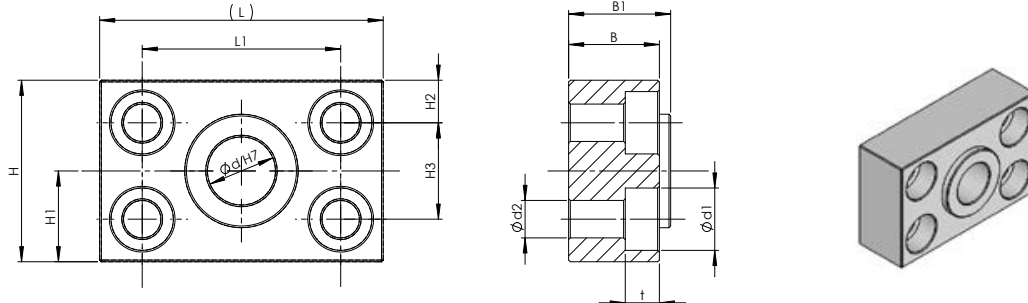

Größe	ϕd^{H7}	ϕd_1	ϕd_2	t	B	B_1	H	H_1	H_2	H_3	L	L_1
KLF-0	10	11	6,6	6,8	16	18	32	16	7,5	17	50	35
KLF-1	15	15	9	9	20	22	36	18	9	18	65	45
KLF-2	20	15	9	9	20	23	40	20	10	20	70	50
KLF-3	25	18	11	11	20	22,5	54	27	12	30	80	58
KLF-4	35	20	13,5	13	30	35	70	35	15	40	100	70
KLF-5	45	33	22	21,5	40	43	80	40	20	40	140	100
KLF-200	70	48	33	32	50	58	125	62,5	30	65	220	160
KLF-300	80	57	39	38	62	70	144	72	34	76	245	180
KLF-400	80	57	39	38	62	70	144	72	34	76	245	180
KLF-500	90	66	45	44	80	90	160	80	40	80	28	200

Kardanlagerbock

zur Lagerung eines Kardanadapters oder eines Schwenklagers.

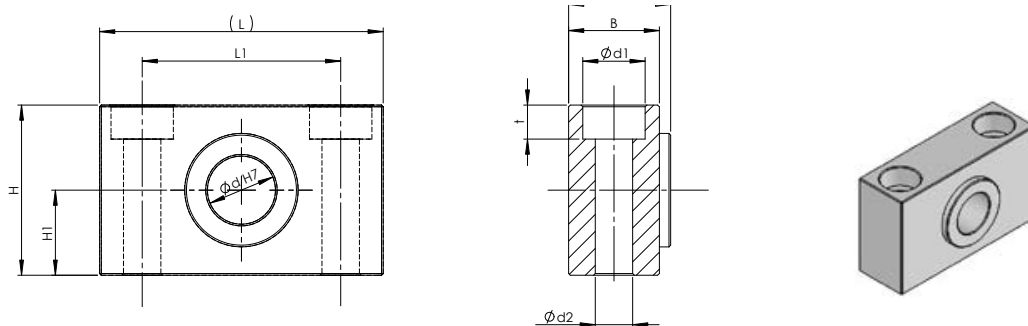

Größe	ϕd^{H7}	ϕd_1	ϕd_2	t	B	B_1	H	H_1	L	L_1
KLB-0	10	11	6,6	6,8	16	18	30	15	50	35
KLB-1	15	15	9	9	20	22	34	17	65	45
KLB-2	20	15	9	9	20	23	38	19	70	50
KLB-3	25	18	11	11	20	22,5	54	27	80	58
KLB-4	35	20	13,5	13	30	35	70	35	100	70
KLB-5	45	33	22	21,5	40	43	80	40	140	100
KLB-100	50	40	26	24,8	50	53	100	50	180	130
KLB-200	70	48	33	32	63	71	124	62	220	160
KLB-300	70	57	39	38	63	71	144	72	245	180
KLB-400	80	57	39	38	63	71	144	72	245	180
KLB-500	90	66	45	44	80	90	160	80	280	200