

Spindelhubgetriebe M/J Bauart VP

Abmessungen

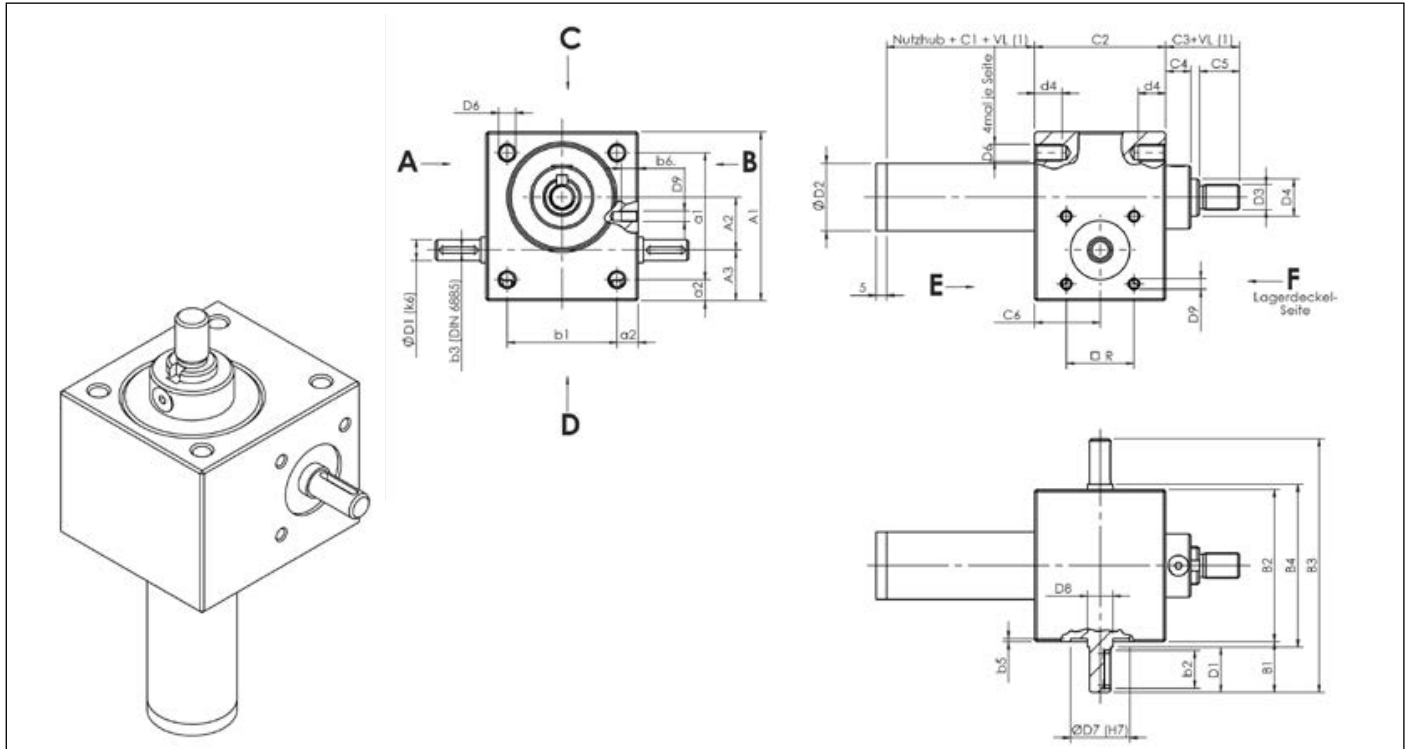

Baugröße	Abmessungen [mm]																
	A ₁	A ₂	A ₃	a ₁	a ₂	B ₁	B ₂	B ₃	B ₄	b ₁	b ₂	b ₃	b ₅	C _{1,TR} ⁽²⁾	C _{1,AS} ⁽³⁾	C ₂	C ₃
M 0	60	20	18	48	6	21	50	92	52	38	14	3	1,5	20	50	50	27
M 1	80	25	24	60	10	24	72	120	77	52	18	3	1,5	20	50	62	35
M 2	100	32	28	78	11	27,5	85	140	90	63	20	5	1,5	30	60	75	45
M 3	130	45	31	106	12	45	105	195	110	81	36	5	2	35	70	82	50
M 4	180	63	39	150	15	47,5	145	240	150	115	36	6	2	40	90	117	65
M 5	200	71	46	166	17	67,5	165	300	170	131	56	8	2,5	55	100	160	95
J 1	210	71	49	170	20	65	195	325	200	155	56	8	8	55	100	175	95
J 2	240	80	60	190	25	67,5	220	355	225	170	56	8	8	60	110	165	110
J 3	240	80	60	190	25	67,5	220	355	225	170	56	8	8	60	110	165	110
J 4	290	100	65	230	30	65	250	380	255	190	56	10	8	65	150	220	140
J 5	360	135	75	290	35	100	300	500	305	230	90	14	8	100	145	266	200

Baugröße	Abmessungen [mm]														
	C ₄	C ₅	C ₆	D _{1k6}	D ₂	D ₃	d ₄	D _{4,Tr}	D _{4,KG}	D ₅	D ₆	D ₇ ^{H7}	D ₈	D ₉ x b ₆	TK □ R
M 0	12	12	25	9 x 20	28	M8	12	Tr14 x 4	1205	26	M6	22	10	(M5 x 6)*	24
M 1	12	19	31	10 x 21,5	32	M12	13	Tr18 x 4	1605	30	M8	32	12	M5 x 6	32
M 2	18	20	37,5	14 x 25	40	M14	15	Tr20 x 4	2005	38,7	M8	35	15	M6 x 10	35
M 3	23	22	41	16 x 42,5	50	M20	15	Tr30 x 6	2505	46	M10	40	17	M8 x 10	44
M 4	32	29	58,5	20 x 45	65	M30	16	Tr40 x 7	4005/4010	60	M12	52	25	M10 x 14	55
M 5	40	48	80	25 x 65	90	M36	30	Tr55 x 9	5010	85	M20	62	28	M12 x 16	70
J 1	40	48	87,5	25 x 62,5	95	M48 x 2	40	Tr60 x 9	–	90	M24	72	28	M12 x 16	70
J 2	40	58	82,5	30 x 65	110	M56 x 2	45	Tr70 x 10	–	105	M30	80	32	M12 x 18	(80)
J 3 (M6)	40	58	82,5	30 x 65	125	M64 x 3	45	Tr80 x 10	8010	120	M30	80	32	M12 x 18	(80)
J 4 (M7)	50	78	110	35 x 62,5	150	M72 x 3	54	Tr100 x 10	–	145	M36	85	40	M16 x 30	(80)
J 5 (M8)	60	118	133	48 x 97,5	180	M100 x 3	80	Tr120 x 14	–	170	M42	90	50	M16 x 40	(115)

* Gewindebohrung für Motorglocke auf Anbauseite A und B Standard nur anzentriert. Gewindebohrung auf Anfrage.
Hinweis: Technische Änderungen vorbehalten.

(1) VL: Spindelverlängerung, siehe Bestellcode
(2) Maß C₁ für Hubgetriebe mit Trapezgewindetrieb
(3) Maß C₁ für Hubgewindetriebe mit Ausdrehsicherung