

# Kugelgewinde- flanschmutter KGF-D

Abmessungen nach DIN 69051

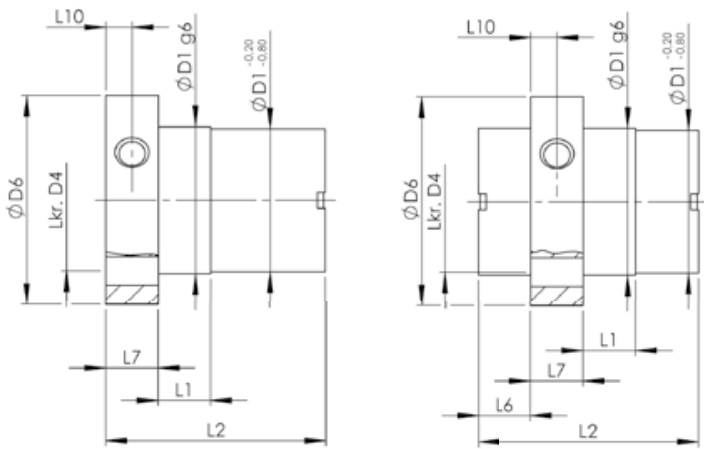

Form E

Form S

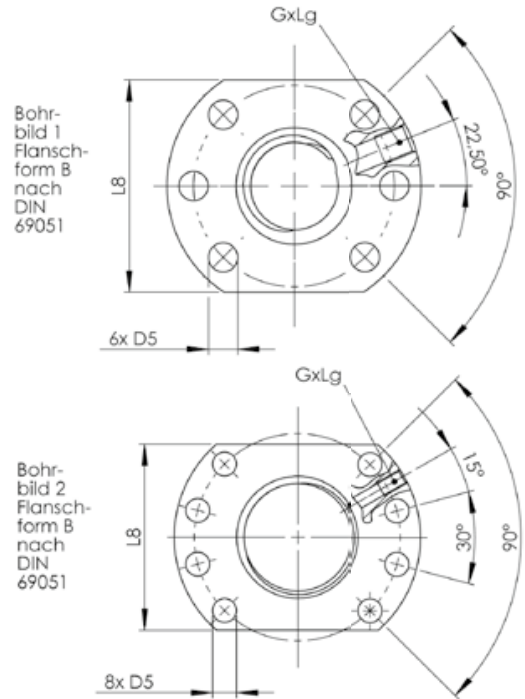
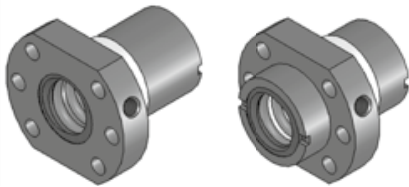

Werkstoff: 1.7131 (ESP65) oder 1.3505 (100 Cr 6)

Typ Durchmesser [mm] Steigung [mm] rechtssteigend	Form	Bohrbild	Abmessungen [mm]										Schmier- bohrung G	Axial- spiel max [mm]	Anzahl der tragen- den Umläufe	Tragzahl [kN]			
			D <sub>1</sub>	D <sub>4</sub>	D <sub>5</sub>	D <sub>6</sub>	L <sub>1</sub>	L <sub>2</sub>	L <sub>6</sub>	L <sub>7</sub>	L <sub>8</sub>	L <sub>9</sub>				L <sub>10</sub>	C <sup>2)</sup>	C <sup>3)</sup>	C <sub>0</sub> = C <sub>0a</sub>
KGF-D 1605 RH-EE	E	1	28	38	5,5	48	10	42	–	10	40	10	5	M 6	0,08	3	12,0	9,3	13,1
KGF-D 1610 RH-EE	E	1	28	38	5,5	48	10	55	–	10	40	10	5	M 6	0,08	6	23,0	15,4	26,5
KGF-D-1616-P8-3 RH-EE	E	1	28	38	5,5	48	10	45	–	10	40	10	5	M 6	0,08	3,75	–	10	16,4
KGF-D 1640-P10-3 RH-EE	S	1	32	42	5,5	52	10	45	10	10	40	8	5	M6	0,08	4	–	8,5	13
KGF-D 2005 RH-EE	E	1	36	47	6,6	58	10	42	–	10	44	10	5	M 6	0,08	3	14,0	10,5	16,6
KGF-D 2505 RH-EE	E	1	40	51	6,6	62	10	42	–	10	48	10	5	M 6	0,08	3	15,0	12,3	22,5
KGF-D 2510 RH-EE	E	1	40	51	6,6	62	16	55	–	10	48	10	5	M 6	0,08	3	17,5	13,2	25,3
KGF-D 2520 RH-EE	S	1	40	51	6,6	62	4	35	10,5	10	48	8	5	M 6	0,15	4	19,0	13,0	23,3
KGF-D 2525 RH-EE	S	1	40	51	6,6	62	9	35	8	10	48	8	5	M 6	0,08	5	21,0	16,7	32,2
KGF-D 2550 RH-EE	S	1	40	51	6,6	62	10	58	10,0	10	48	8	5	M 6	0,15	5	22,5	15,4	31,7
KGF-D 3205 RH-EE	E	1	50	65	9	80	10	55	–	12	62	10	6	M 6	0,08	5	24,0	21,5	49,3
KGF-D 3210 RH-EE <sup>5)</sup>	E	1	53 <sup>1)</sup>	65	9	80	16	69	–	12	62	10	6	M 8x1	0,08	3	44,0	33,4	54,5
KGF-D 3220 RH-EE	E	1	53 <sup>1)</sup>	65	9	80	16	80	–	12	62	10	6	M 6	0,08	4	42,5	29,7	59,8
KGF-D 3260-P10-3,5 RH-EE	S	1	53	65	9	80	16	68	10	12	62	10	6	M 6	0,08	4,8	–	20	49,3
KGF-D 4005 RH-EE	E	2	63	78	9	93	10	57	–	14	70	10	7	M 6	0,08	5	26,0	23,8	63,1
KGF-D 4010 RH-EE	E	2	63	78	9	93	16	71	–	14	70	10	7	M 8x1	0,08	3	50,0	38,0	69,1
KGF-D 4020 RH-EE	E	2	63	78	9	93	16	80	–	14	70	10	7	M 8x1	0,08	4	44,5	33,3	76,1
KGF-D 4040 RH-EE	S	2	63	78	9	93	16	85	7,5	14	– <sup>4)</sup>	10	7	M 8x1	0,08	8	42,0	35,0	101,9
KGF-D 5010 RH-EE	E	2	75	93	11	110	16	95	–	16	85	10	8	M 8x1	0,08	5	78,0	68,7	155,8
KGF-D 5020 RH-EE	E	2	85 <sup>1)</sup>	103 <sup>1)</sup>	11	125	22	95	–	18	95	10	9	M 8x1	0,08	4	82,0	60,0	136,3
KGF-D 6310 RH-EE	E	2	90	108	11	125	16	97	–	18	95	10	9	M 8x1	0,08	5	86,0	76,0	197
KGF-D 8010 RH-EE	E	2	105	125	13,5	145	16	99	–	20	110	10	10	M 8x1	0,08	5	–	82,7	221,9
linkssteigend																			
KGF-D 2005 LH-EE	E	1	36	47	6,6	58	10	42	–	10	44	10	5	M 6	0,08	3	16,5	10,5	16,6

<sup>1)</sup> nicht nach DIN 69051.

<sup>2)</sup> Dynamische Tragzahl nach DIN 69051 Teil 4 Entwurf 1978.

<sup>3)</sup> Dynamische Tragzahl nach DIN 69051 Teil 4 Entwurf 1989.

<sup>4)</sup> Flansch rund.

<sup>5)</sup> Auch mit Ø 50 nach DIN lieferbar.

# Kugelgewinde- flanschmutter KGF-N

Abmessungen nach NEFF-Norm

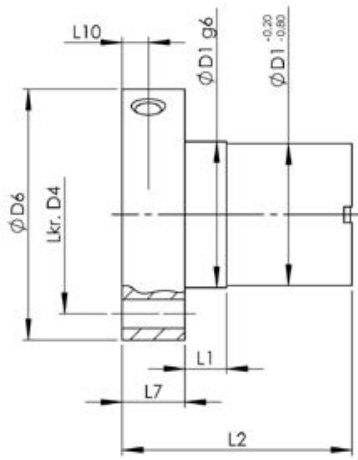

Form E

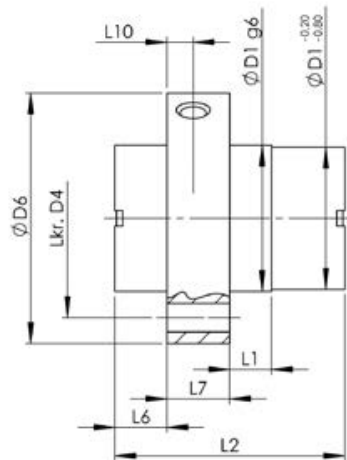

Form S

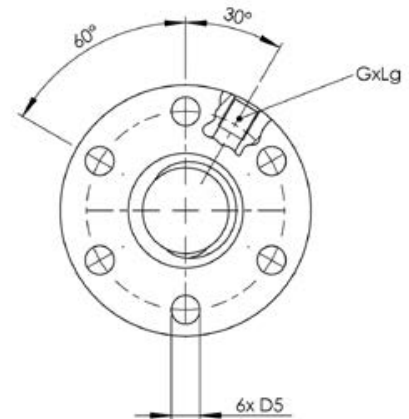

Bohrbild 3  
Neff Norm



Werkstoff: 1.7131 (ESP65) oder 1.3505 (100 Cr 6)

Typ Durchmesser [mm] Steigung [mm] rechtssteigend	Form	Abmessungen [mm]										Schmier- bohrung G	Axial- spiel max [mm]	Anzahl der tragenden Umläufe	Tragzahl [kN]		
		D <sub>1</sub>	D <sub>4</sub>	D <sub>5</sub>	D <sub>6</sub>	L <sub>1</sub>	L <sub>2</sub>	L <sub>6</sub>	L <sub>7</sub>	L <sub>g</sub>	L <sub>10</sub>				C <sup>1)</sup>	C <sup>2)</sup>	C <sub>o</sub> = C <sub>oa</sub>
KGF-N 1605 RH-EE	E	28	38	5,5	48	8	44	–	12	8	6	M 6	0,08	3	12,0	9,3	13,1
KGF-N-1616-P8-3-RH-EE	E	28	38	5,5	48	8	45	–	12	8	6	M 6	0,08	3,75	–	10	16,4
KGF-N 2005 RH-EE	E	32	45	7	55	8	44	–	12	8	6	M 6	0,08	3	14,0	10,5	16,6
KGF-N 2020 RH-EE	S	35	50	7	62	4	30	8	10	8	5	M 6	0,08	4	12,0	11,6	18,4
KGF-N 2050 RH-EE	S	35	50	7	62	10	56	8	10	8	5	M 6	0,15	5	18,0	13,0	24,6
KGF-N 2505 RH-EE	E	38	50	7	62	8	46	–	14	8	7	M 6	0,08	3	15,0	12,3	22,5
KGF-N 3205 RH-EE	E	45	58	7	70	10	59	–	16	8	8	M 6	0,08	5	24,0	21,5	49,3
KGF-N 3210 RH-EE	E	53	68	7	80	10	73	–	16	8	8	M 8x1	0,08	3	44,0	33,4	54,5
KGF-N 3240 RH-EE	S	53	68	7	80	14	45	7,5	16	10	8	M 6	0,08	4	17,0	14,9	32,4
KGF-N-3260-P10-3,5 RH-EE	F	53	68	7	80	16	68	10	16	8	8	M 6	0,08	4,8	–	20	49,3
KGF-N 4005 RH-EE	E	53	68	7	80	10	59	–	16	8	8	M 6	0,08	5	26,0	23,8	63,1
KGF-N 4010 RH-EE	E	63	78	9	95	10	73	–	16	8	8	M 8x1	0,08	3	50,0	38,0	69,1
KGF-N 5010 RH-EE	E	72	90	11	110	10	97	–	18	8	9	M 8x1	0,08	5	78,0	68,7	155,8
KGF-N 6310 RH-EE	E	85	105	11	125	10	99	–	20	8	10	M 8x1	0,08	5	86,0	76,0	197,0
KGF-N 8010 RH-EE	E	105	125	13,5	145	10	101	–	22	8	11,5	M 8x1	0,08	5	–	82,7	221,9

<sup>1)</sup> Dynamische Tragzahl nach DIN 69051 Teil 4 Entwurf 1978.

<sup>2)</sup> Dynamische Tragzahl nach DIN 69051 Teil 4 Entwurf 1989.